

Salvajor TroughVeyor

Model TVL & TVR

Trough Conveying and Food Waste Disposing System

Installation & Operating INSTRUCTIONS

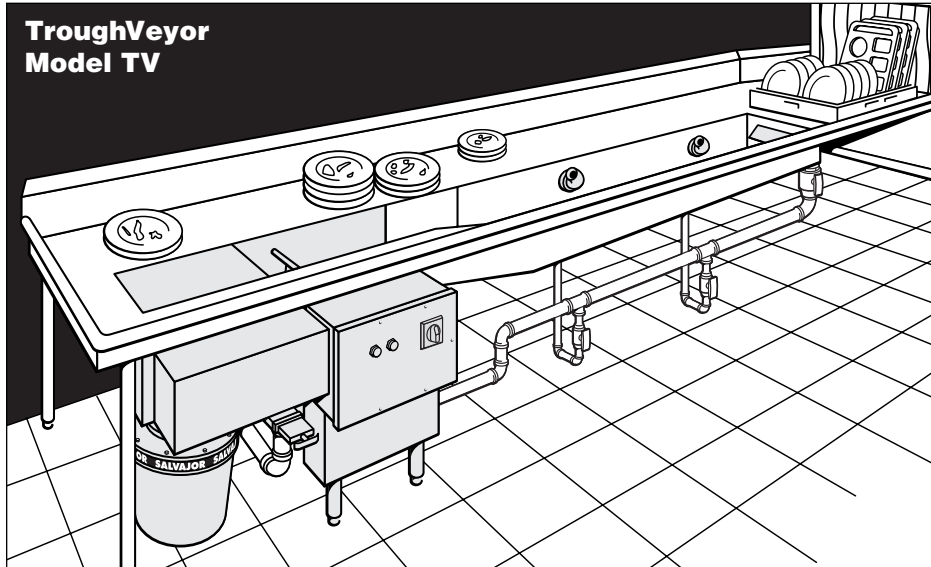

**Models Available: 300-TRV, 500-TRV, 750-TRV
300-TVL, 500-TVL, 750-TVL**

2	Typical Installations and Table Cutout
3	Trough Recirculation
4	Attaching Disposer
	Warranty and Reply Card
5	Plumbing
6	Electrical
7	Operating Instructions
8	How it Works

**ALL INSTALLATIONS SHOULD BE MADE IN ACCORDANCE WITH
LOCAL AND NATIONAL PLUMBING AND ELECTRICAL CODES.**



(Disposer not included in NSF listing)



The Salvajor Company 4530 East 75th Terrace Kansas City, Missouri 64132-2081, USA

1-888-SALVAJOR

FAX: 1-800-832-9373

www.salvajor.com

Email: sales@salvajor.com

service@salvajor.com

Manufacturers of Commercial Food Waste Disposing Systems since 1944

Typical TroughVeyor Installations

Model TVL & TVR

Conveys waste into a Salvajor disposer.
Trough design for multiple operators.

LEFT HAND OPERATIONS:

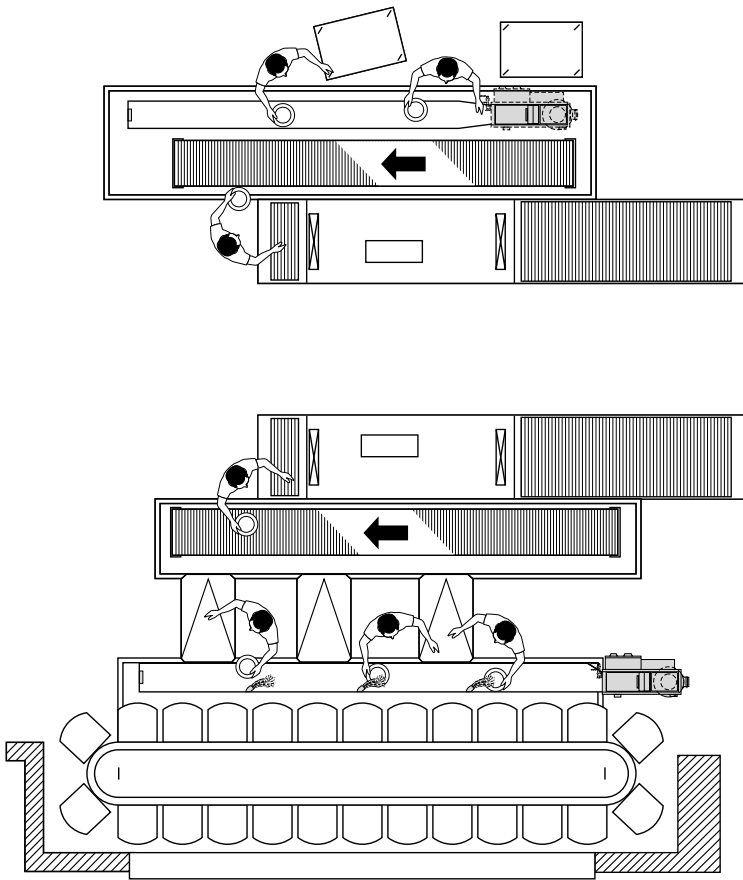

RIGHT HAND OPERATIONS:

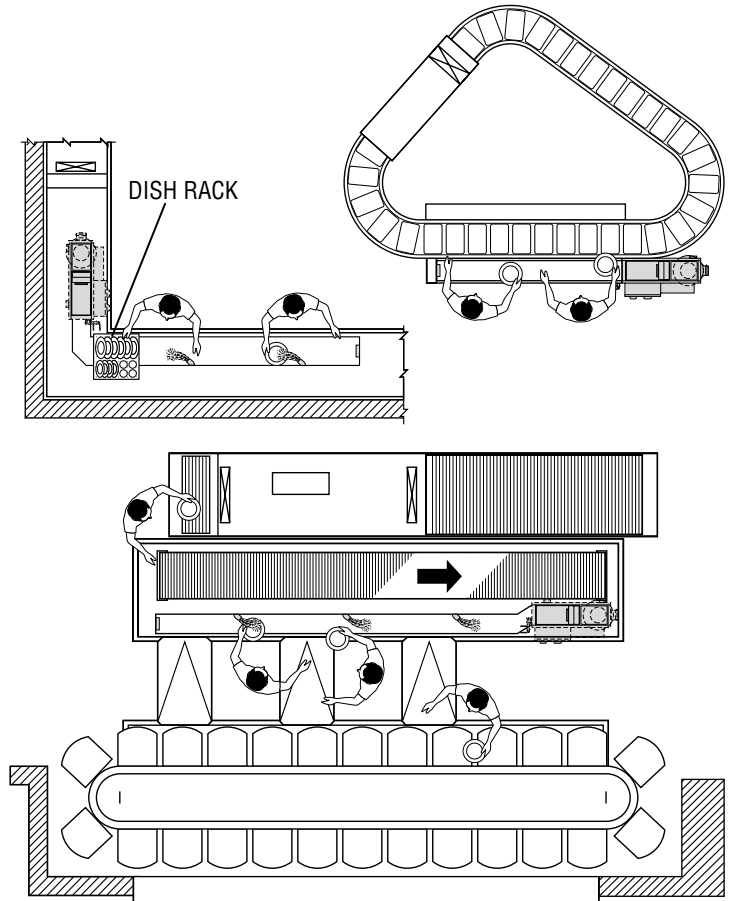

There are options available to you in locating the Salvajor TroughVeyor in the dishtable. We suggest you review the following illustrations before proceeding. Left hand shown, right hand similar.

It is important that you take into account the Salvajor TroughVeyor has a 1½" flange on three (3) sides and these flanges must butt up to the underside of the table. If the fabricated trough is located at the front edge of the table, it will be necessary to offset the TroughVeyor where it meets the fabricated trough.

If preferred, the fabricated trough may be set in from the front edge of the table.

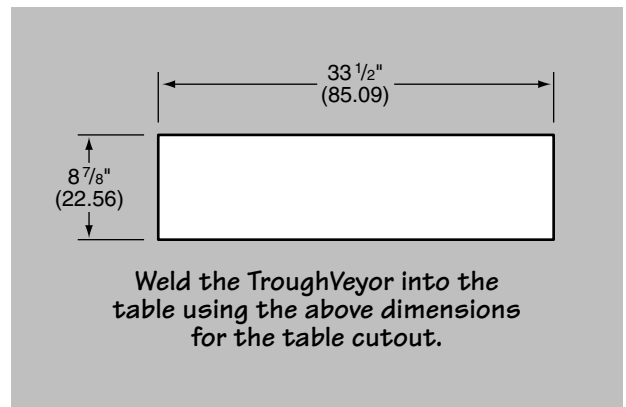
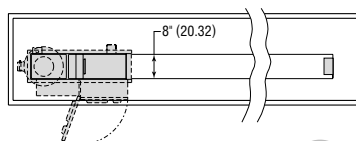
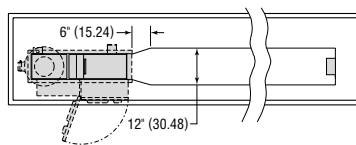
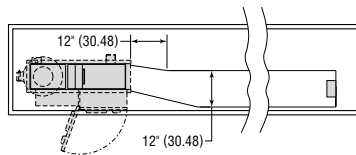
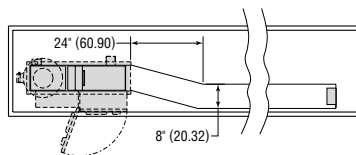

Weld the TroughVeyor into the table using the above dimensions for the table cutout.

Trough Recirculation

Plumb 1½" pipe from the 1½" rubber coupler supplied on the end of the TroughVeyor unit to the far end of the fabricated trough and attach it to the water diffuser.

A 1½" valve must be installed as close to the end of the fabricated trough as possible to regulate pump flow capacity.

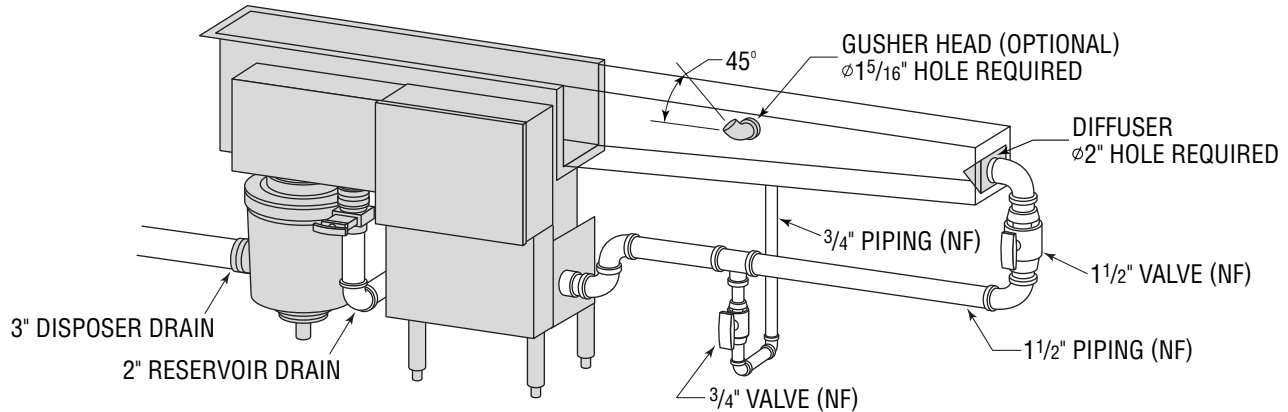

If optional gusher heads are to be mounted along the fabricated trough for scrapping and preflushing, they should be connected to the main 1½" recirculation line reducing to 3/4"

with a 3/4" valve in each gusher head line to regulate the flow. Configure gusherhead plumbing as shown to reduce splash when starting TroughVeyor.

MAKE ALL PLUMBING CONNECTIONS IN ACCORDANCE WITH NATIONAL AND LOCAL PLUMBING CODES.

The closed end of the fabricated trough should have a minimum depth of 3" and a fall of at least 3/32" per running foot so that there will be adequate drainage to the TroughVeyor machine.

The open end of the fabricated trough should have a flange opening to match the flange opening on the TroughVeyor. The two flange openings are to be butted together and securely welded.

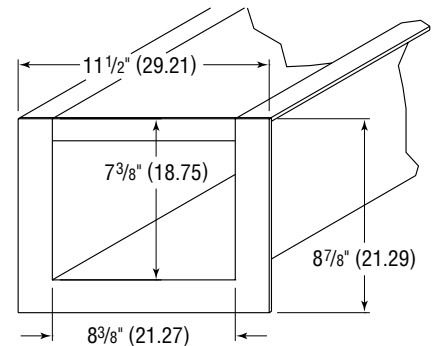

A 2" diameter hole is required at the closed end of the trough for the factory furnished water diffuser which ensures a proper water flow pattern down the trough.

Center the 2" diameter hole 1¼" from the bottom of the trough. A 1½" union can be used instead of the 1½" sweat fitting when the plumbing will need to be disconnected.

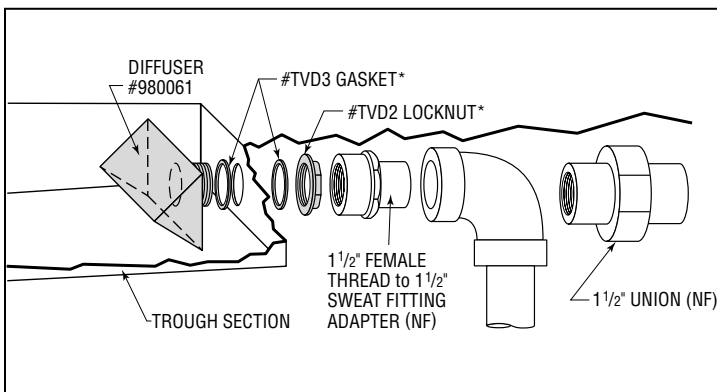

Attaching Disposer

1. Carefully remove the top housing assembly by removing the eight bolts making sure not to damage the center gasket.
2. Apply lubricant to the rubber collar on top housing and the beaded collar on the transition of the TroughVeyor.
3. Slip the top housing assembly up onto the beaded collar and tighten the clamp so the top housing assembly can not be pulled down over the bead. (Cut out rubber baffles of hycar adaptor to reduce bridging of food waste.)
4. Measure distance from the bottom of the top housing to floor.
5. Turn the disposer on its side and install the leg support on the bottom of the disposer and adjust the leg extension so the disposer will stand approximately 1/2" below the bottom of the top housing.
6. Carefully balancing the disposer on the leg support, walk it to the bottom of the top housing, aligning the ears on the shredder ring with the locking tabs of the top housing.
7. Slide the center gasket into place. Insert the top housing bolts through holes in the top housing and into the disposer body housing. As you the tighten bolts, the disposer will pull up securely to the top housing.
8. Extend the leg extension securely on the floor and tighten the set screws.

NOTE: It is important that the leg fit tightly between the disposer and the floor.

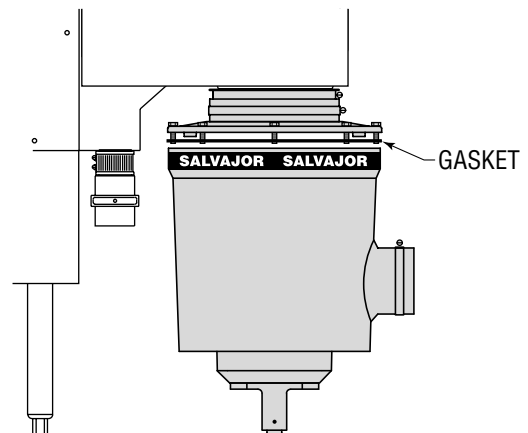
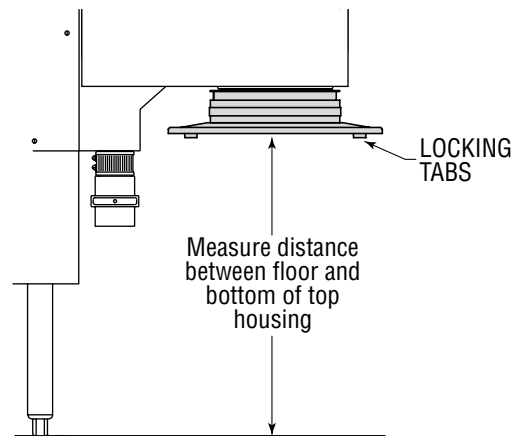
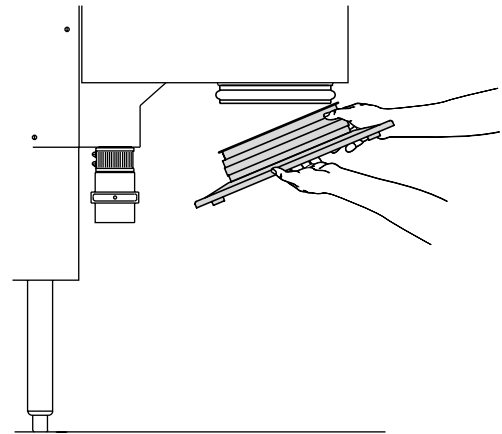

STOP!
If you have any questions about this installation
call 1-888-SALVAJOR for installation advice.

Plumbing

WATER SUPPLY

The Salvajor TroughVeyor is designed for easy plumbing installation. The solenoid valves are factory installed and are attached to an automatic water blender which will introduce water tempered to approximately 107° F.

Plumb 3/4" lines from both hot and cold water supply sources and reduce to 1/2" before attaching to corresponding valves on the TroughVeyor water harness.

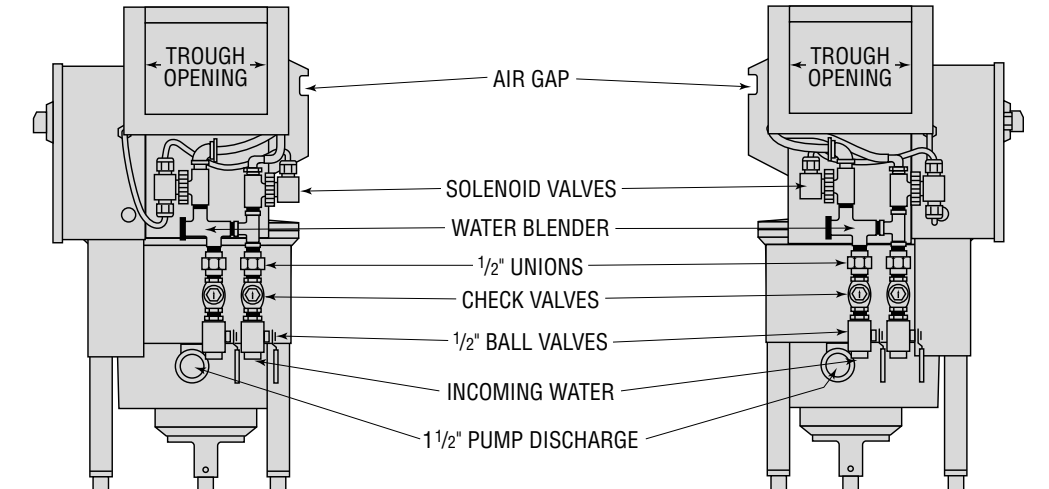

IMPORTANT:

The TroughVeyor is equipped with an approved air gap, eliminating the need for vacuum breakers. The Uniform Plumbing Code states that air gaps are accepted as replacements for vacuum breakers with foodwaste disposing systems.

NOTE:

To assure against leaks, tighten water harness fittings. They may come loose during shipment, fabrication or installation. Pressure regulators should be installed in areas where water pressure exceeds the recommended maximum of 80 psi.

DRAIN PIPING

There are two (2) drain connections to be made on the TroughVeyor system. The TroughVeyor reservoir tank drain is supplied with a simple quick-opening drain valve using a 2" rubber coupler to connect

to your 2" drain pipe. 3" piping is recommended for the disposer drain. These two (2) drain lines can be run separately to floor drains or can be tied together using a WYE and/or a sanitary Tee fitting if space allows.

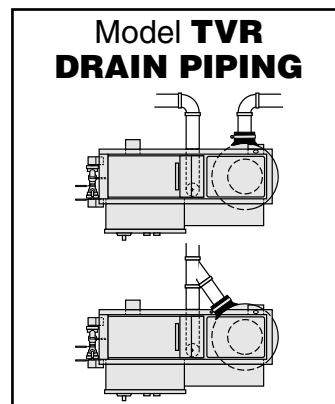
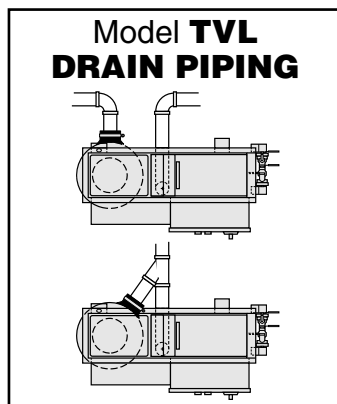

MAKE ALL PLUMBING CONNECTIONS IN ACCORDANCE WITH NATIONAL AND LOCAL PLUMBING CODES.

Electrical

ELECTRICAL

The Salvajor TroughVeyor is designed for easy electrical installation. Components such as the pump motor, solenoids, separator motor, etc. are all factory pre-wired. The field wiring on the TroughVeyor consists of two (2) simple steps.

First, wire from the disposer to the 1/2" knockout provided for you on the control panel that is located on the front of the TroughVeyor.

Second, run power from the power source to the control panel. A 1/2" knockout is provided on the water harness side of the control panel.

Complete wiring diagrams will be found inside the TroughVeyor control panel. The disposer wiring diagram will be found attached to the junction box cover located on the bottom of the disposer, as well as in the disposer installation manual.

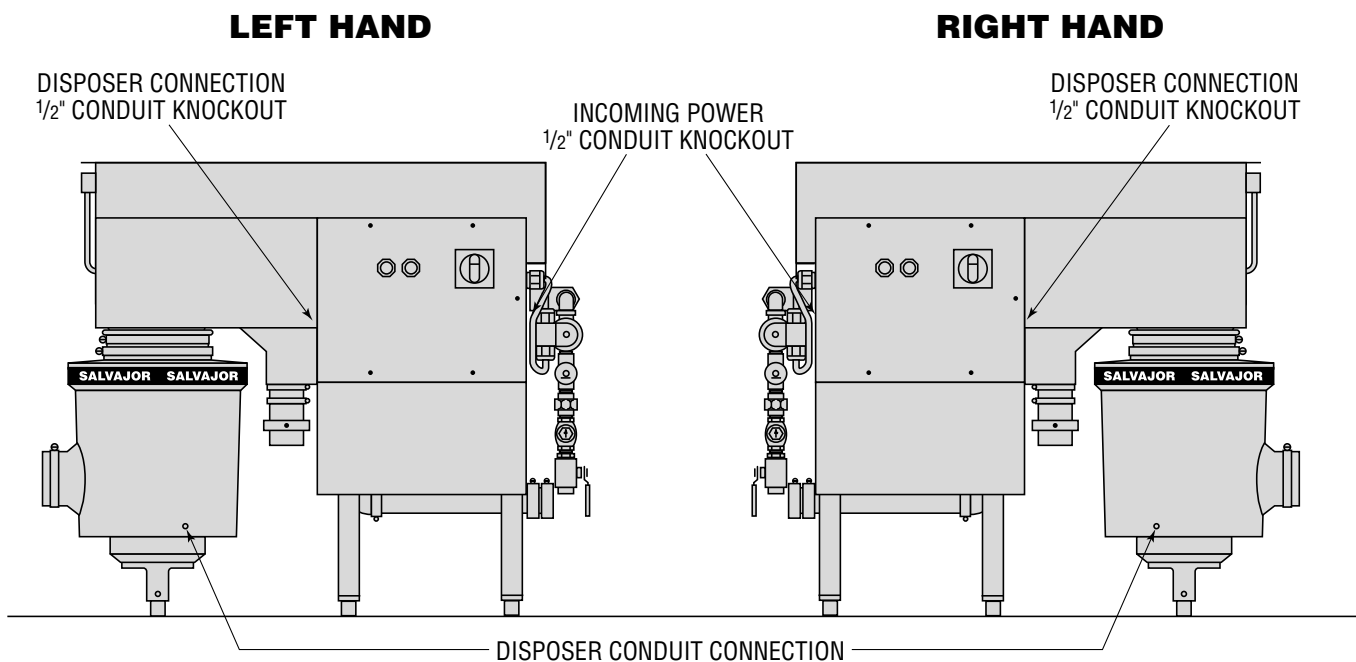

IMPORTANT:

The pump must be checked for proper rotation. When facing the front of the pump located on the bottom of the TroughVeyor, the proper rotation is clockwise.

NOTE:

The TroughVeyor is equipped with a safety lid switch which is located at the safety cover over the disposer. The safety lid switch is activated whenever the disposer safety cover is opened, cutting power to the TroughVeyor system.

ALL 3 PHASE/TOTAL FULL LOAD AMPS

MODEL	208V	230V	460-480V	TOTAL HP
300-TV	12.64	11.66	5.83	3.92
500-TV	17.64	16.16	8.13	5.92
750-TV	23.64	21.66	10.83	8.92

NOTE:

Always use watertight conduit and fittings when wiring this product.

MAKE ALL INSTALLATIONS IN ACCORDANCE WITH LOCAL AND NATIONAL ELECTRICAL CODES.

Operating Instructions

TO START:

- 1 Close DRAIN VALVE.
- 2 Position RESERVOIR SCREENS in bottom of tank.
- 3 Lower SALVAGE BASIN over reservoir screens.
- 4 Lower SAFETY COVER over disposer.
- 5 Press START button on CONTROL PANEL. Allow time for reservoir tank to fill and maintain a constant flow of water down the trough.
- 6 Adjust THE RECIRCULATION VALVE to regulate the flow of water.
- 7 If gusher heads are being used along the trough, adjust the GUSHER HEAD VALVES individually to the desired settings.

TO STOP:

- A Press STOP button on the CONTROL PANEL.
- B Open DRAIN VALVE.
- C Allow time for trough to drain. Raise SALVAGE BASIN.
- D Remove RESERVOIR SCREENS from tank. Do not dump waste in tank! Rinse SALVAGE BASIN, SCREENS, tank interior and separator discs thoroughly.

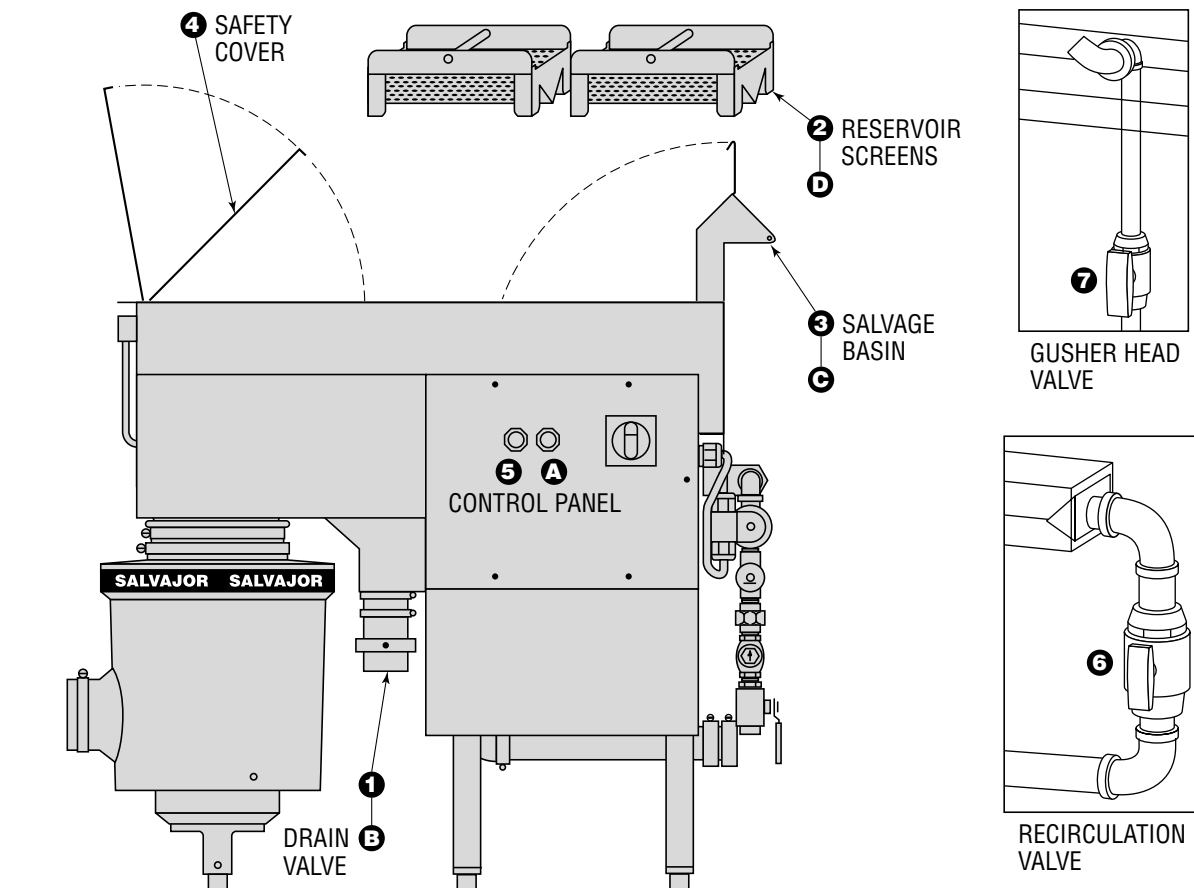

How it Works

Visit salvajor.com and view videos of the TroughVeyor in action

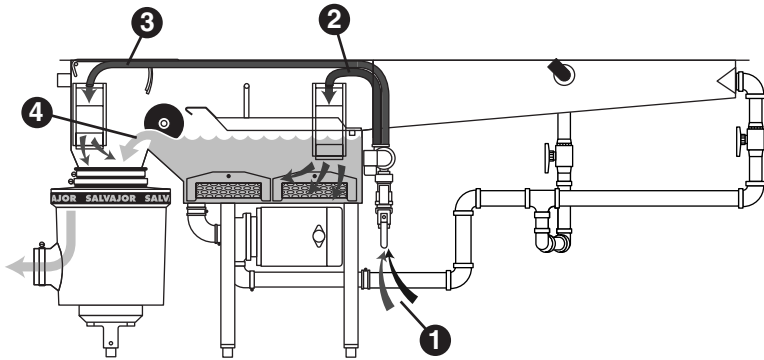

- 1 When the TroughVeyor is first turned on, hot and cold water pass through a water blender set at 107° F.
- 2 The blended water enters the tank at the rate of 5 gallons per minute.
- 3 Cold water is introduced directly into the disposer grind chamber at the rate of 2 gallons per minute.
- 4 The water level in the tank reservoir rises until it overflows into the disposer at the rate of 5 gallons per minute.

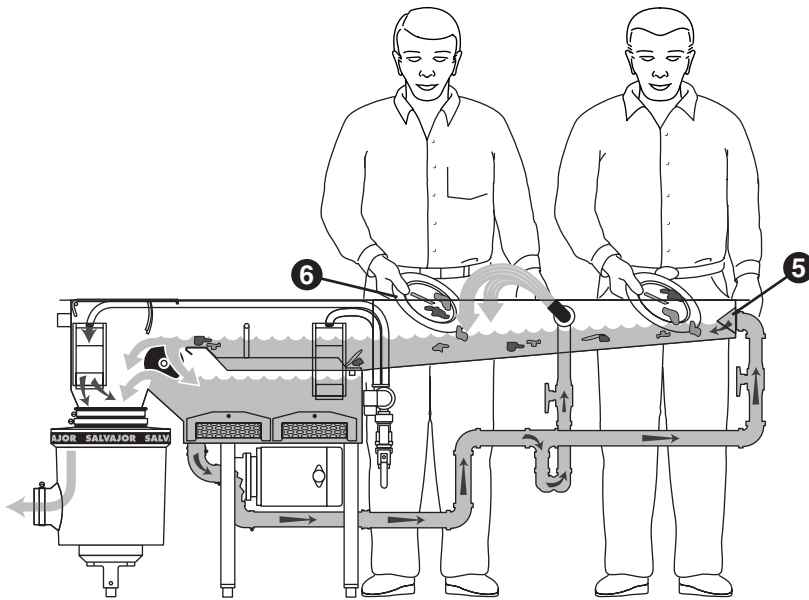

- 5 When the tank reservoir holds sufficient water, the TroughVeyor pump begins circulating water down the trough.
- 6 Dishes are scrapped into the trough by hand or passed through the water plume coming from the rubber gusher heads (optional).

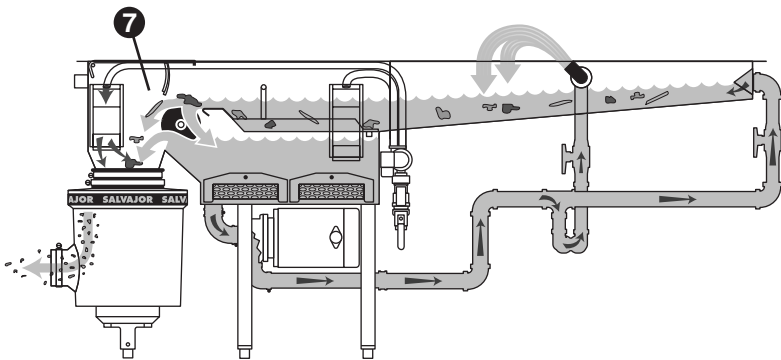

- 7 Food waste is carried by the water toward the revolving separator discs. Water falls through the discs and returns to the tank reservoir. The waste is carried over the discs into the disposer for grinding.